

# Crack Propagation Trajectory For Kenaf Fibre Composite Under Quasi Static Loading

Nurul Alya Zahari, Zaleha Mohamad\*

Faculty of Mechanical and Manufacturing Engineering, Universiti Tun Hussein Onn Malaysia, Johor 86400, Malaysia

\* Corresponding Email: [zaleha@uthm.edu.my](mailto:zaleha@uthm.edu.my)

**Abstract** – The cracking of the composites are worthy the attention in order to expect in which manner of failure might occur. This matter should be not underestimated because of a safe structure may fail with even microscopic flaws. The crack propagation trajectory and effects of the hole in woven and non-woven fibre orientations for epoxy based kenaf composites under quasi static loading are investigated. The shape of the work specimens is square thin plate with thickness of 3 mm. There are two types of orientations of work specimen used which are the non-woven random and plain woven with 0° and 90° fibre orientation. These work specimens made by hand lay-up method. There are three setting conditions of the work specimen used in this research such as single edge crack, single edge crack with hole, and double edge crack with two holes. The experiments of tensile tests were carried out to determine the strength of the epoxy based kenaf composites. The specimens were subjected to a concentrated load at the upper edge and fixed at the lower edge. From the data attained, indicated that fibre orientation has a significant role in defining the ultimate tensile strength. The main objective of this research is to investigate the crack propagation trajectory for epoxy based kenaf composites under quasi static loading. It shows that from the results obtained, the crack trajectories for single edge crack is a straight line. However, the existence of the hole rearrange the stress or strain field. The crack will curved towards the hole. Meanwhile, for double edge cracks with two holes, the cracks move to the near hole. The cracks then reoriented horizontally as the cracks have reformed the stress distribution at each other's tip. After that, the cracks then captivated again by the opposite holes and curved towards the holes. It was found that there is no significant difference between the crack propagation for non-woven and woven fibre orientation samples.

**Keywords:** Crack propagation trajectory, Kenaf fibre composite, Random woven

Submitted: 19 August 2020 - Revised: 31 August 2020 - Accepted: 06 September 2020

## 1. Introduction

Investigations focused on the usage of the natural fibre as filler and reinforce in polymer matrix composites have significantly growing these days. In order to produce composite materials, kenaf, sisal, flax, bamboo, hemp, jute and ramie are several examples of most familiar natural fibres used as reinforcement biodegradable. A good interfacial adhesion with the matrix is the foremost obligation in composites that make natural fibre as reinforcement [1]. Additionally, Mohanty [2] also Mustapa [3] identified that natural fibres are relatively high strength and specific stiffness, a renewable, have a low density and a low equipment abrasion.

Moreover, in many applications, natural fibres which cost saving out weight high composite performance requirements can substitute the synthetic fibres [4]. However, Ribot et al. [5] stated that the primary

problem of natural fibre in composite is the absorption of moisture of the fibre which drops the tolerable processing temperature incompatible between hydrophobic polymer and hydrophilic natural fibre.

As a likely crop for replacement tobacco, the Malaysia government has acknowledged kenaf or its scientific name *Hibiscus cannabinus* L. Based on Akil et al. [6], the bast and core fibres from kenaf have been used to make composites for the building industry, furniture and car components. Aji et al. [7] mentioned that due to have a more content of cellulose, ranging up to 70 % compared to the kenaf core fibre and the others type natural fibre and their high characteristics, long kenaf bast fibres have likely for reinforcement polymers.

In order to boost the physical and mechanical properties of the composite reinforced natural fibres such as hemp, pineapple, banana and jute, many previous researchers used numerous type of chemical treatment to. Additionally, Akil et al. [6] investigated that the alkaline



treatment or mercerization by NaoH is the broadly used for natural fibre, particularly kenaf fibre provided preferable mechanical properties such as impact strength, strength modulus, flexural strength, and flexural modulus for composites.

The fatigue behavior of natural fibre composites is still not completely understood. Abdullah et al. [8] carried out a studies based on natural fibre composites. The effect of different stress level on tension-tension fatigue behavior and fibre content ratio is investigated. It was found that the fibre content ratio influences the fatigue life intensely.

Among all natural fibre composite applications, the construction and automotive were the major segment. The natural fibre composites generate vast potential to substitute competing materials as it provides a significant performance at lesser prices. The most preferred by the automotive were the bast fibre such as hemp, kenaf, flax and jute, whereas the material of choice by the construction and building was the wood plastic composites. Many previous investigations studied the performance of the kenaf reinforced in composites which comprises the manufacturing process [7], the consequence of natural fibre strength in composites [6], and delamination of layer. The increasing demand of using natural fibre in this recent year, give opportunities to investigate the crack propagation direction in the natural fibre.

This research is aimed to investigate the crack propagation trajectory and effects of the hole in woven and non-woven fibre orientations for epoxy based kenaf composites under quasi static loading. The cracking of the composites are worthy the attention in order to expect in which manner of failure might occur. This matter should be not underestimated because of a safe structure may fail with even microscopic flaws and replacing components of engineering structures may be wasteful and costly.

## 2. Methodology

In this research, two types of kenaf fibre orientations used which were the non-woven random and plain woven with 0° and 90° fibre orientation. The plain woven kenaf fibre was formed from kenaf yarns. The yarns count used are 3.00 mm with 3 ply. The plain woven fibre produced by using the table loom as shown in Figure 1 by the interlacement of warp and weft yarns. During the fabrication of the composite, it is important to define their composition in order to determine the mechanical properties of the fibre reinforcement and resin matrix. The reinforcement that was used in this research is kenaf natural fibre. Meanwhile, epoxy resin was used as the matrix. The composition of epoxy and hardener was 2:1.

The composites were prepared by mixing the epoxy and Kenaf fibre. The epoxy resin is significant as a

bonding material of composite plates. For the non-woven form, the mixture of fibre and resin then were poured into the prepared mold. In opposition, for the woven form, the kenaf fibre mat must be cut into the size of the mold which then weighted to identify the composition. Then, the hand lay-up method used to form the composite. The required amount of epoxy resin was taken. The epoxy then poured on the fibre that placed in the mold. In order to infuse the fibres with the resin and confiscated voids, a roller was used. Then, the mold was pressed using hot/cold compression machine under pressure 8 MPa for 2 hours. After being compressed, the resin was then dried in room temperature. After curing, the composite plate was detached from the mold. The plates were trimmed into desired dimensions.

The specific shape and dimension of work specimen used according to the respective setting conditions which are single edge crack, single edge crack with hole and double edge cracks with two holes. The thickness of the work specimens is 3 mm. Single edge crack, single edge crack with hole, and double edge cracks with two holes are illustrated respectively in Figure 2–4.



Figure 1. Weaving of kenaf yarns using table loom

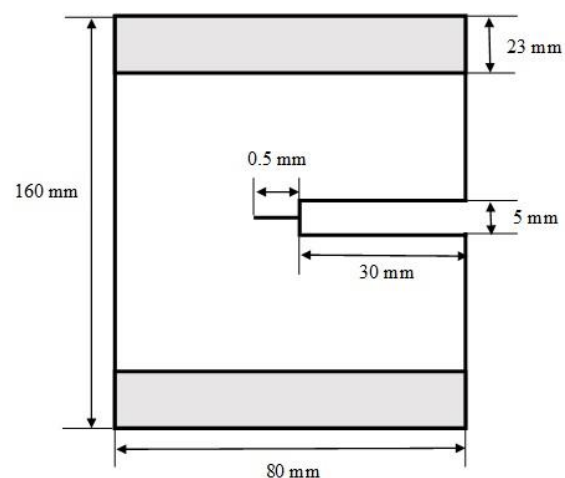

Figure 2. Single edge crack



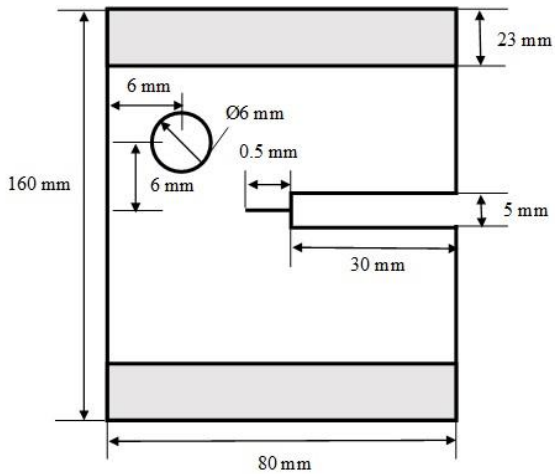

Figure 3. Single edge crack with hole

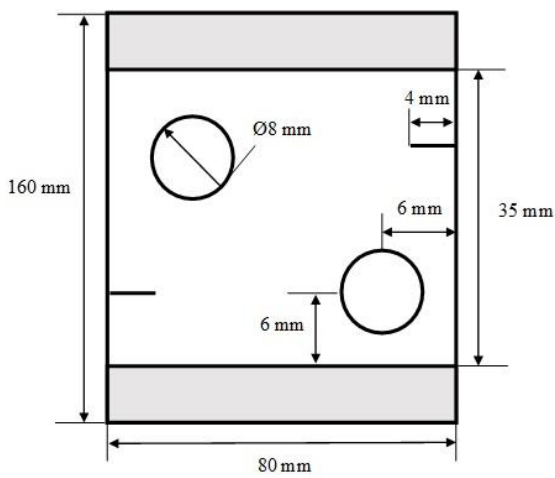

Figure 4. Double edge crack with two holes

### 3. Results and Discussion

#### 3.1. Tensile Test

In this research, the tensile test were performed to investigate the crack propagation trajectory for epoxy based kenaf composites under quasi static loading and the strength of the composites. Basically, the plates subjected to a concentrated load at the upper edge and fixed at the lower edge. The effect of hole to the crack propagation trajectory was determined during this test. By the end of this test, the different between the crack propagation between the woven and non-woven fibre orientations were identified. Figure 5 specifies the distribution of ultimate tensile strength against fibre orientations.

According to Shibata [9], the strength of woven fibre composites be influenced by the bonding between the matrix and fibre, fibre orientation and on the weave style. The ultimate tensile strength of the plain woven fibre orientation composite was compared with non-woven random fibre orientation composites with the similar content which is 15% by weight of fibre. As expected, the

fibre with woven orientation composites produced greater ultimate tensile strength compared to non-woven fibre orientation composites. This might be because of stress transfer at a uniform distribution with the application of tensile load in both the transverse and longitudinal directions. In general, the fibres are interlaced in both the warp and weft directions in the plain woven composites which sequentially lessens the desirable properties of the composite [10].

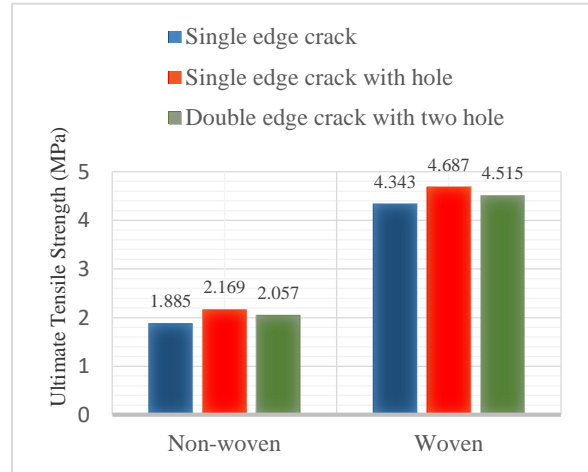

Figure-5. Effects of fibre orientations on the ultimate tensile strength

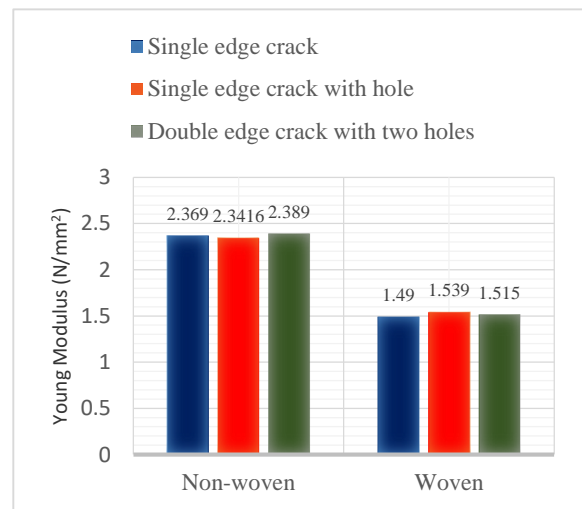

Figure 6. Young Modulus for non-woven and woven kenaf fibre orientation

Conversely, as shown in Figure 6, the Young Modulus for the non-woven random fibre orientation composites are greater than the plain woven fibre orientation composites. This is because the non-woven random fibre orientation composites have lower strain to failure. As a result, brittle failure mechanism for the non-woven fibre orientation composites occurred. Ismail and Che [11] said that the stress cannot be transfer correctly along the fibre as the low failure strain of the discontinuous amorphous matrix. Therefore, a faster crack propagation



rate created which causing the composites to break at a lower failure strain. From the data, it can be observed that the samples made up from plain woven fibre orientation have the higher strength compare to the samples made up from non-woven random fibre orientation for all three conditions.

### 3.2. Crack Propagation Trajectory

The samples were projected under mode I loading until broken. The crack propagation trajectories then are evaluated for each conditions. The crack propagate slowly as the uniformly increasing of force applied. According to Griffith's criterion, if the strain energy release rate during crack growth is higher enough to surpass the rate of rise in surface energy related with the formation of new crack surfaces, the crack will propagate.

Figure 7 shows the example of crack trajectory behaviour of single edge crack for non-woven random fibre orientation composites. Based on the data acquired, the crack propagation trajectory of all the single edge crack for non-woven fibre orientation composites samples nearly the same. It is indicated that the crack propagate in a straight line. While, Figure 8 shows the result obtained in the previous research by Hao et al. [12].

The material that this researcher used was non-woven kenaf reinforced polypropylene composites. The geometries of the composite samples between this research and previous research were not the same. However, it specifies that the behaviour of the crack propagation attained were alike. The load–displacement reactions generally follow a linear path, with their moduli slowly decreasing when reaching greater strain levels. Besides, the crack would always propagate in a straight line as the stress intensity distribution along the fibre is uniform.



(a)



(b)

Figure 7. Crack trajectories of single edge crack samples for non woven fibre orientation. (a) example of the specimen (b) enlargement of the crack



Figure 8. Experimental crack propagation trajectory done by Hao [12]

According to the data obtained, the crack propagation trajectory of all the single edge crack for plain woven fibre orientation composites samples almost similar. Figure 9 specifies the example of crack trajectory behavior of single edge crack for plain woven fibre orientation composites. It is showed that the crack move in a straight line. Figure 10 displays the result gained in the previous research by Ismail and Che [11].

The material that this researcher used was woven yarn kenaf fibre reinforced polyester composites. The behavior of the crack propagation obtained were similar regardless the geometries of the composite samples between this research and previous research were not similar. Abdunaser [13] said that originally the crack would propagate in a straight line if there is no hole at the work specimen.



(a)



(b)

Figure 9. Crack trajectories of single edge crack samples for woven fibre orientation. a) example of the sample b) enlargement of the crack



Figure 10 : Experimental crack propagation trajectory done by Ismail and Che [11]

Figure 11 displays the example of crack trajectory behaviour of single edge crack with hole for non-woven random fibre and woven orientation composites. Based on the figure, the crack propagation trajectory for both

cracks propagate towards the hole as it move close to the hole. Initially, the crack propagate in a straight line but slowly when near the hole, the crack curved towards the hole. Figure 12 shows the result obtained by simulation in the previous research by Abdunaser [13].

The material that this researcher used was polymethylmethacrylate (PMMA) composites. The behaviour of the crack propagation attained were alike although the geometries of the composite samples between this research and previous research were almost the same. For mode loading I, the crack would propagate in a straight path if there was no hole at the plate. Conversely, due to the existence of the hole, the crack curved towards the hole instead. The cracks are probable to commence at a hole boundary due to stress concentration effect. A curvilinear crack trajectories formed on each samples as the existence of the hole on the samples rearrange the stress or strain fields.



(a)



(b)

Figure 11: Crack trajectories of single edge crack with hole samples (a) for non-woven fibre orientation. (b) for woven fibre orientation



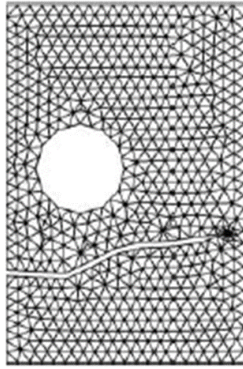

Figure 12: Simulation crack propagation trajectory done by Abdalnaser [13]

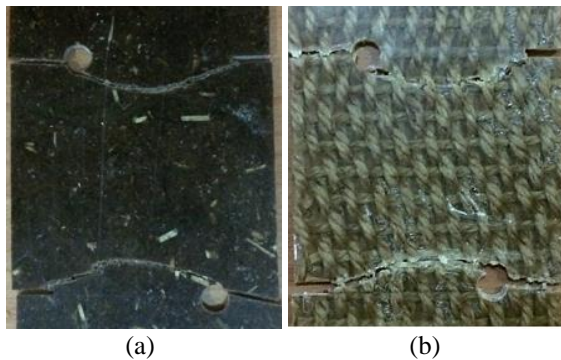

Figure 13: Crack trajectories of double edge cracks with two holes samples (a) for non-woven fibre orientation. (b) for woven fibre orientation

Figure 13 depicts the crack trajectory behaviour of double edge cracks with two holes. From the observation, it shows that each crack propagates to the close hole. Since the cracks have altered the stress distribution at each other's tip, the cracks reoriented horizontally. Once more, the cracks then fascinated again by the opposite holes and curved towards the holes

#### 4. Conclusion

The main objective of this research is to investigate the crack propagation trajectory for epoxy based kenaf composites under quasi static loading. It shows that from the results obtained, the crack trajectories for single edge crack is a straight line. However, the existence of the hole rearrange the stress or strain field. The crack will curved towards the hole. Meanwhile, for double edge cracks with two holes, the cracks move to the near hole.

The cracks then reoriented horizontally as the cracks have reformed the stress distribution at each other's tip. After that, the cracks then captivated again by the opposite holes and curved towards the holes. The crack propagation between non-woven and woven fibre orientation epoxy based kenaf composites also differentiated. It was found that there is no significant difference between the crack propagation for non-woven

and woven fibre orientation samples. Comparison between the present results and those obtained by previous researcher shows that there are good agreement for crack trajectory.

#### References

- [1] Gassan, J. (2000). A study of fibre and interface parameters affecting the fatigue behavior of natural fibre composites. *Journal of Applied Science and Manufacturing*, vol. 3, no. 33, pp. 369-374.
- [2] Mohanty, A.K., Misra, M., Drzal, L. T., Selke, S.E., Harte, B.R., and Hinrichsen, G. (2005). *Natural Fibers, biopolymers and biocomposites*. CRC Press, London.
- [3] Mustapa, M. S., Latif, N. A., Mohd Joharudin, N. F., Mahzan, S., Masirin, M. I. M., & Hamid, N. A. (2018). The Effect of Heat Treatment on Compression Strength of Recycled AA6061 Aluminium Chips. In *Materials Science Forum* (Vol. 934, pp. 124-128). Trans Tech Publications Ltd.
- [4] Oksman, K., Skrifvars, and Selin, J.F. Natural fibers as reinforcement in polylactic acid (PLA) composites. *Composite Science and Technology*, pp 1317- 1324.
- [5] Ribot, N.M.H., Ahmad, Z., and Mustaffa, N.K. (2011). Mechanical properties of kenaf fiber composite using co-cured in-line fiber joint. *International Journal of Engineering Science and Technology*, vol3 no 4, pp. 3526-3534.
- [6] Akil, H.M., Omar, M.F., Mazuki, A.A.M., Safiee, S., Ishak, Z.A.M., and Bakar, A. (2011). Kenaf fiber reinforced composites: A review. *Material and Design*, pp. 4107-4121.
- [7] Aji, I.S., Sapuan, S.M., Zainudin, E.S., and Abdan, K. (2009). Kenaf fibres as reinforcement for polymeric composites: A review. *International Journal of Mechanical and Materials Engineering*, pp. 239-248.
- [8] Abdullah, A.H., Alias, S.K., Jenal, N., Abdan, K., and Ali, A. (2012). Fatigue Behavior of Kenaf Fiber Reinforced Epoxy Composites. *Engineering Journal*, pp. 105-113.
- [9] Shibata, S, Cao, Y. and Fukumoto, I. (2005). Press forming of short natural fiber-reinforced biodegradable resin: Effects of fiber volume and length on flexural properties,
- [10] Yahaya, R., Sapuan, S. M., Jawaid, M., Leman, Z., & Zainudin, E. S. (2016). Mechanical performance of woven kenaf-Kevlar hybrid composites," *J. Reinf. Plast. Compos.*, vol. 33, no. 24, pp. 2242-2254.
- [11] Ismail, A. E., and Che, A. A. M. A. (2015). Tensile strength of woven yarn kenaf fiber reinforced polyester composites. *Journal of Mechanical Engineering and Sciences. Polymer Testing*, Volume 24, Issue 8, 1005-1011
- [12] Hao, A., Yuan, L., & Chen, J. Y. (2015). Notch effects and crack propagation analysis on kenaf/polypropylene nonwoven composites. Elsevier.
- [13] Abdalnaser, A. M. (2008). Effect of Holes under Quasi-Static Loading on Crack Propagation Trajectory.

